

EHS High Precision HV Modules 8 Channels with Single Channel Floating-GND

Operator's manual



Contents

1. General information
2. Technical data
3. Handling
 - 3.1 Connection
 - 3.2 Limits
 - 3.3 Safety Loop
 - 3.4 Option: Single Channel INHIBIT
4. Pin assignment and connector layout
5. Order Information

CAN-Interface Operator's Manual

Attention!

-It is not allowed to use the unit if the covers have been removed.

-We decline all responsibility for damages and injuries caused by an improper use of the module. It is highly recommended to read the manual before any kind of operation.

Note

The information in this manual is subject to change without notice. We take no responsibility for any error in the document. We reserve the right to make changes in the product design without notification to the users.

Filename EHS82x-F as of 2011-06-10

1. General information

This EHS is a High Precision multichannel high voltage power supply in 6U Eurocard format. The output voltage has extraordinary high stability, lowest ripple and noise and very low temperature coefficient. Each single channel is independently controllable with voltage and current control. The current measurement includes two measurement ranges with resolution down to a few picoampere. The data for set and measure values is given in a format of Floating Point Single Precision values. The modules are equipped with 24 bit ADC and 20 bit DAC circuits.

The outputs RTN - floating HV-GND - of each channel are floating against each other and against the ground (with a 25 V hardware limit). Optional the floating voltage can be increased to up to 200 V.

The HV output at the module is available as a 51 pin REDEL HV connector (up to 6 kV), isolated built-in SHV connectors (up to 8 kV) or KINGS connectors (10 kV).

This manual covers modules with 4 or 8 channels. For output voltages up to 6 kV these modules are also available with 16 channels (see manual "EHS High Precision HV Modules 16 Channels with Single Channel Floating-GND")

2. Technical data

	EHS 82 05x-F ¹⁾	EHS 82 10x-F ¹⁾	EHS 82 20x-F ¹⁾	EHS 82 30x-F ¹⁾	EHS 82 40x-F ¹⁾	EHS 82 60x-F ¹⁾	EHS 82 80x-F ¹⁾	EHS 42 100x-F ¹⁾	
HV channels per module	8	8	8	8	8	8	8	4	
Output voltage $V_{O\ nom}$ [kV]	0.5	1	2	3	4	6	8	10	
Output current $I_{O\ nom}$ [mA]	10	8	4	3	2	1	1	0.5	
Resolution of voltage setting ^{*)} [mV]	1	2	5	10	10	12	20	20	
current setting ^{*)} [nA]	30	20	10	5	4	2	2	1	
voltage measurement ^{*)} [mV]	1	2	5	10	10	12	20	20	
current measurement ^{*)} [nA] 1 st measurement range $I_{O\ nom} \geq I_O \geq 20\ \mu A$	8	5	4	3	2	1	1	1	
current measurement ^{*)} [pA] 2 nd measurement range $20\ \mu A \geq I_O > 0$	50	50	50	50	50	50	50	50	
*) with standard sample rate 50/s and digital filter 64									
Ripple and noise [mV _{P-P}]	5					20		30	
	- at max. load and $ V_O > 1\% * V_{O\ nom}$ - $f > 10\ Hz$								
Stability (no load/load and ΔV_{IN})	$0.01\% * V_{O\ nom}$								
Sample rates [samples/s]	5, 10, 25, 50, 60, 100, 500								
Digital filter averages	1, 16, 64, 256, 512, 1024								
The resolution of measurable values depends on the settings of the sampling rate and the digital filter!									
Accuracy of voltage measurement	$\pm (0.01\% * V_O + 0.02\% * V_{O\ nom})$								
Accuracy of current measurement	1 st measurement range $\pm (0.1\% * I_O + 0.02\% * I_{O\ nom})$				2 nd measurement range $\pm (0.1\% * I_O + 4\ nA)$				
The measurement accuracy is guaranteed in the range $1\% * V_{O\ nom} < V_O \leq V_{O\ nom}$ and for 1 year									
Voltage ramp up / down [V/s]	$1 * 10^{-6} * V_{O\ nom}$ up to $0.2 * V_{O\ nom}$								
Floating voltage	Connector RTN to GND: $\leq 20\ V $								

	EHS 82 05x-F ¹⁾	EHS 82 10x-F ¹⁾	EHS 82 20x-F ¹⁾	EHS 82 30x-F ¹⁾	EHS 82 40x-F ¹⁾	EHS 82 60x-F ¹⁾	EHS 82 80x-F ¹⁾	EHS 42 100x-F ¹⁾	
Temperature coefficient	$< \pm 50 * 10^{-6}/K$								
Hardware limits V_{max} / I_{max}	potentiometer per module (V_{max} / I_{max} is the same for all channels)								
Interface	CAN-Interface (potential free)								
Operating mode	Full module and channel control via CAN interface in EHS mode: EDCP (Enhanced Device Control Protocol) or EHQ mode: DCP (Device Control Protocol) see manual "CAN-Interface Operator's Manual"								
Module status	green LED turns on if all channels have the status "ready"								
Protection loop (I_s) potential free (2 pin Lemo-socket and REDEL SL)	$5 \text{ mA} < I_s < 20 \text{ mA} \Rightarrow$ module on $I_s < 0.5 \text{ mA} \Rightarrow$ module off								
Option K: INHIBIT per channel	Via Sub-D-9 connector INHIBIT (TTL level)								
INHIBIT 0-7 / Channel	0	1	2	3	4	5	6	7	GND
Sub-D-9 connector / PIN	1	2	3	4	5	6	7	8	9
Power requirements V_{INPUT}	+ 24 V (< 4 A) and + 5 V (< 0.2 A)								
Packing	6U Euro cassette (40.64 mm wide and 220 mm deep)								
Connector on the rear	96-pin connector according to DIN 41612								
HV connector	51 pin REDEL HV connector (R51) up to 6 kV isolated built-in SHV connector (SHV) up to 8 kV Isolated built-in KINGS connector (KNG) 10 kV								
Operating temperature	0 ... +40 °C								
Storage temperature	-20 ... +60 °C								

)1 x=p polarity positiv, x=n polarity negativ

3. Handling

3.1 Connection

The supply voltages and the CAN interface are connected to the module via a 96-pin connector on the rear side of the module.

The module is controlled in the selected CAN operating mode, the factory setting is "EHS mode".

3.2 Limits

The maximum output voltage for all channels (hardware voltage limit) is defined through the position of the corresponding potentiometer V_{max} .

The maximum output current for all channels (hardware current limit) is defined through the position of the corresponding potentiometer I_{max} .

The greatest possible set value for voltage and current is given by $V_{max} - 2\%$ and $I_{max} - 2\%$, respectively.

It is possible to measure the hardware voltage and current limits at the sockets below the potentiometer. The socket voltages are proportional to the relative limits, where 2.5 V corresponds to $102 \pm 2\% V_{O\text{ nom}}$ and $102 \pm 2\% I_{O\text{ nom}}$.

The output voltage and current are limited to the specified value. If a limit is reached or exceeded in any channel the green LED on the front panel turns off.

3.3 Safety Loop

A safety loop can be implemented via the safety loop socket (SL) on the front panel and between the SL-contacts (Pin 22 and PIN 30) at the REDEL-connector if equipped. If the safety loop is active then an output voltage in any channel is only present if the safety loop is closed and an external current in a range of 5 to 20 mA of any polarity is driven through the loop. (For modules with a REDEL-connector the other SL input must be closed.) If the safety loop is opened during the operation the output voltages are shut off without ramp and the corresponding bits in the 'ModuleStatus' (see manual "Operator's Manual CAN-Interface" 5.5.2.1 ModuleStatus) and ModuleEventStatus (5.5.2.3 ModuleEventStatus) are cancelled. After closing the loop again the ModuleEventStatus has to be reset and the channels have to be switched ON.

The loop connectors are potential free, the internal voltage drop is approx. 3 V. In the factory setup the safety loop is not active (the corresponding bits are always set). The loop can be activated by removing the internal jumper. (see manual "Operator's Manual CAN-Interface", app. B).

3.4 Option: Single Channel INHIBIT

Optionally it is possible to install an INHIBIT for each channel via the Sub-D connector. Channel 0 to 7 corresponds to Pin 1 to 8 at the Sub-D connector, Pin 9 is connected to GND. Internally the inputs can be connected either with a pull down (option IND) or a pull up resistor (option INU).

If the INHIBIT contact pin (n) is connected to the GND or a TTL-LOW potential then the HV-PS on this channel is switched OFF permanently without ramp and the green LED on front panel turns off.

The INHIBIT active time (LOW potential) must be at least 100 ms!

When the INHIBIT is no longer active (TTL-HIGH potential or not connected), the INHIBIT flag must be reset before the voltage can be switched ON again (5.5.1.3 Channel event status).

4. Pin assignment and connector layout

Pin assignment of the 96-pin connector according to DIN 41612:

pin		pin		pin		comment
a1	+5V	b1	+5V	c1	+5V	power supply
a3	+24V	b3	+24V	c3	+24V	
a5	GND	b5	GND	c5	GND	
a11	@CAN_GND	b11	@CAN_L	c11	@CAN_H	CAN bus interface, potential free
a13	/RESET	b13	/HW_RMPDWN			external control signals
a30	A4	b30	A5			address field: set module address (A0 ... A5); connected to GND => address bit = 0 open => address bit = 1
a31	A2	b31	A3	c31	GND	
a32	A0	b32	A1	c32	GND	

/RESET	active low; global reset of the module; HV generation is stopped immediately
/HW_RMPDWN	pulse form: high – low – high
	pulse-width: 1µs ... 100µs
	function: ramp down of all channels immediately, with a ramp speed of $V_{nom}/50s$ Note: after activating this signal the ram speed is set to $V_{nom}/50s$

51 pin REDEL HV connector

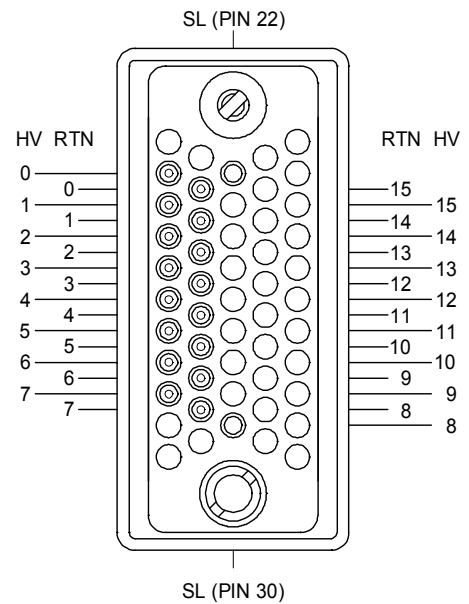

5. Order Information

Item Code	Type	Polarity	Channels	V _{nom}	I _{nom}	HV Connector
EH042100p504FKNG	EHS 42100p-F	positive	4	10000V	0.5mA	Kings
EH042100n504FKNG	EHS 42100n-F	negative	4	10000V	0.5mA	Kings
EH082-80p105FSHV	EHS 8280p-F	positive	8	8000V	1mA	SHV
EH082-80n105FSHV	EHS 8280n-F	negative	8	8000V	1mA	SHV
EH082-60p105FR51	EHS 8260p-F	positive	8	6000V	1mA	REDEL ¹⁾
EH082-60n105FR51	EHS 8260n-F	negative	8	6000V	1mA	REDEL ¹⁾
EH082-40p205FR51	EHS 8240p-F	positive	8	4000V	2mA	REDEL ¹⁾
EH082-40n205FR51	EHS 8240n-F	negative	8	4000V	2mA	REDEL ¹⁾
EH082-30p305FR51	EHS 8230p-F	positive	8	3000V	3mA	REDEL ¹⁾
EH082-30n305FR51	EHS 8230n-F	negative	8	3000V	3mA	REDEL ¹⁾
EH082-20p405FR51	EHS 8220p-F	positive	8	2000V	4mA	REDEL ¹⁾
EH082-20n405FR51	EHS 8220n-F	negative	8	2000V	4mA	REDEL ¹⁾
EH082-10p805FR51	EHS 8210p-F	positive	8	1000V	8mA	REDEL ¹⁾
EH082-10n805FR51	EHS 8210n-F	negative	8	1000V	8mA	REDEL ¹⁾
EH082-05p805FR51	EHS 8205p-F	positive	8	500V	10mA	REDEL ¹⁾
EH082-05n805FR51	EHS 8205n-F	negative	8	500V	10mA	REDEL ¹⁾

¹⁾ Option SHV instead of R51 => Connector SHV